

Scaffold Safety

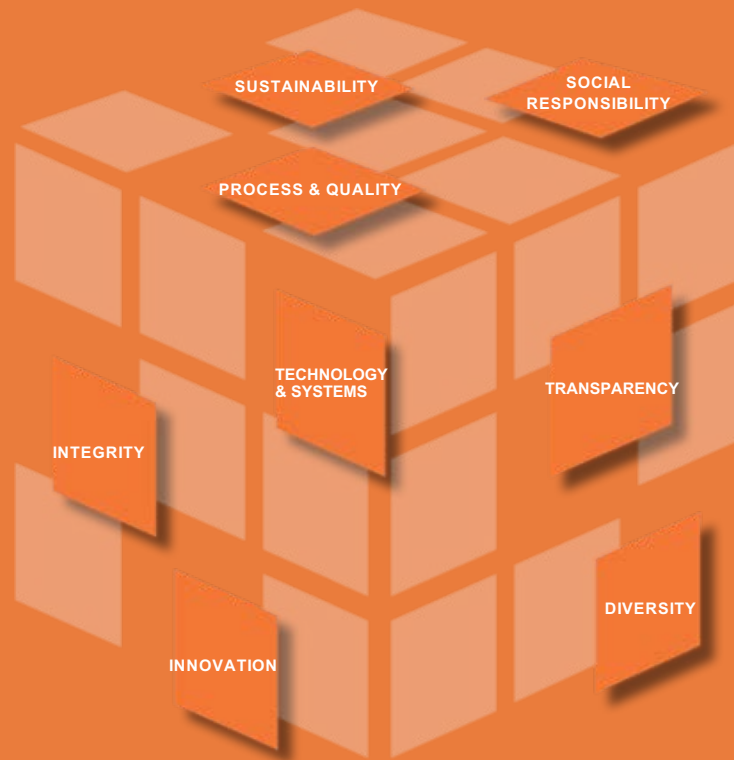



This presentation will outline examples, standards and best practices to help you stay safe while working on scaffolds.

During the module you will answer Quick Quizzes to help you review and test your understanding; these are not scored.

There is also a short quiz, in addition to this module, which will be scored. It is necessary to pass with a score of 80% or better to receive credit for this module. This module will take 20 minutes to complete.

**A scaffold is an elevated, temporary work platform.
There are three basic types:**

- Supported scaffolds – platform supported by rigid, load bearing members, such as poles, legs, frames & outriggers.
- Suspended scaffolds – platforms suspended by ropes or other non-rigid overhead support.
- Aerial Lifts – such as “cherry pickers” or “boom trucks”.



Employees working on scaffolds are exposed to these hazards:

- Falls from elevation – caused by slipping, unsafe access, and the lack of fall protection
- Struck by falling tools/debris
- Electrocution – from overhead power lines
- Scaffold collapse - caused by instability or overloading
- Bad planking giving way



Falls may occur:

- While climbing on or off the scaffold
- Working on unguarded scaffold platforms
- When scaffold platforms or planks fail



If a worker on a scaffold can fall more than 10 feet, protect them by:

- Guardrails
- Personal Fall Arrest Systems (PFAS) - a system used to arrest an employee's fall. It consists of an anchorage, connectors, a body belt or body harness and may include a lanyard, deceleration device, lifeline, or combinations of these.



Here are some guidelines for guardrails:

- Install along open sides & ends.
- Front edge of platforms should not be more than 14 inches from the work, unless using guardrails and/or PFAS.
- Top rails should be 38 to 45 inches tall.
- There should be mid rails halfway between top rail and platform.
- Toe boards should be at least 3-1/2 inches high.



Guardrails are not required:

- When the front end of all platforms is less than 14 inches from the face of the work
- When outrigger scaffolds are three inches or less from the front edge
- When employees are plastering and lathing 18 inches or less from the front edge

Which of the following statements is correct?

- A. Top rails should be 38 to 45 inches tall.
- B. There should be mid rails halfway between top rail and platform.
- C. Toe boards should be at least 3-1/2 inches high.
- D. All of the above.

Which of the following statements is correct?

- A. Top rails should be 38 to 45 inches tall.
- B. There should be mid rails halfway between top rail and platform.
- C. Toe boards should be at least 3-1/2 inches high.
- D. All of the above.**

You must be trained how to properly use PFAS. PFAS include anchorage, lifeline and body harness. What will a personal fall arrest system do to protect you?

A personal fall arrest system places the employee into a body harness that is fastened to a secure anchorage so that he/she cannot fall. Body belts are not acceptable as personal fall arrest systems.

A few key requirements:

- There should be no free fall more than 6 feet.
- There should be prompt rescue after a fall.
- Inspect PFASs prior to each use.
- Don't use PFASs until they've been inspected by a competent person. A competent person must determine the feasibility and safety of providing fall protection for employees erecting or dismantling supported scaffolds.



What fall protection will you need when working on scaffolds?

- ▶ Boatswains' chair, catenary scaffold, float scaffold, needle beam scaffold, ladder jack scaffold – personal fall arrest system
- ▶ Single-point or two-point adjustable scaffold – personal fall arrest system and a guardrail system
- ▶ Crawling board (chicken ladder) – personal fall arrest system, a guardrail system or by a three-fourth inch diameter grab line or equivalent handhold securely fastened beside each crawling board
- ▶ On a walkway within a scaffold – guardrail system installed within 9 ½ inches of and along at least one side of the walkway



The ends of this scaffold are not properly guarded.

What fall protection will you need when working on scaffolds?

- ▶ On a supported scaffold when performing overhand bricklaying operations – personal fall arrest system or guardrail system on all open sides and ends of the scaffold.
- ▶ For all other scaffolds, use a personal fall arrest system or a guardrail system. In general:
 - Use PFAS instead of guardrails on some scaffolds.
 - Use PFAS & guardrails on suspension scaffolds.
 - Use PFAS on erectors and dismantlers where feasible.



The ends of this scaffold are not properly guarded.

You can protect yourself from falling objects:

- Wear hardhats.
- Barricade area below scaffold to forbid entry into that area.
- Use panels or screens if material is stacked higher than the toe board.
- Build a canopy or erect a net below the scaffold that will contain or deflect falling objects.



Which of the following statements are correct about Personal Fall Arrest Systems (PFAS)?

- A. Inspect PFASs prior to each use.
- B. Don't use PFASs until they've been inspected by a competent person.
- C. PFASs only have to be inspected once a week.
- D. A and B
- E. B and C

Which of the following statements are correct about Personal Fall Arrest Systems (PFAS)?

- A. Inspect PFASs prior to each use.
- B. Don't use PFASs until they've been inspected by a competent person.
- C. PFASs only have to be inspected once a week.
- D. A and B**
- E. B and C

The possibility of electrocution is a serious consideration when working near overhead power lines.

A great best practice is never less than 10 feet.

Check the clearance distances listed in the OSHA Standard (29 CFR 1926.45(f)(6)).

Scaffolds may be closer to power lines than specified where the clearance is necessary to perform work, but only after the utility company, or electrical system operator, is notified of the need to work closer and they de-energized or relocate the lines, or installed protective coverings to prevent contact with the lines.



Cinder blocks or other similar materials should not be used to support a scaffold because they could be crushed. Any time there is inadequate support, improper construction or a shift in the components of the scaffold (including the base upon which the structure is built), there is danger of collapse.

An example of good support



Mud Sills

Base Plate



Inadequate support? In danger of collapse?

- ▶ Use appropriate scaffold construction methods.
- ▶ Provide proper scaffold access.
- ▶ Properly use a competent person.



Platforms must:

- ▶ Be fully planked or decked with no more than 1 inch gaps, and
- ▶ Be able to support its weight & up to 4 times its weight as a maximum load.
- ▶ Each scaffold platform and walkway must be at least 18 inches wide.
- ▶ When the work area is less than 18 inches wide, guardrails and/or personal fall arrest systems must be used.
- ▶ Employees on a walkway located within a scaffold must be protected by a guardrail system installed within 9 1/2 inches of and along at least one side of the walkway. Planking should be graded and marked as scaffold planking.



Properly constructed scaffold.



This is not a properly constructed scaffold!

- ▶ There should be no large gaps in front edge of platforms.
- ▶ Platforms that are 10' and less to extend at least 6" but not more than 12" past support unless designed and installed and/or guarded properly.
- ▶ Platforms should be greater than 10' and no more than 18" past support unless designed and installed and/or guarded properly.
- ▶ Each abutted end of plank must rest on a separate support surface.
- ▶ Overlap platforms must be at least 12 inches over supports, unless restrained to prevent movement.

Planks not properly overlapped

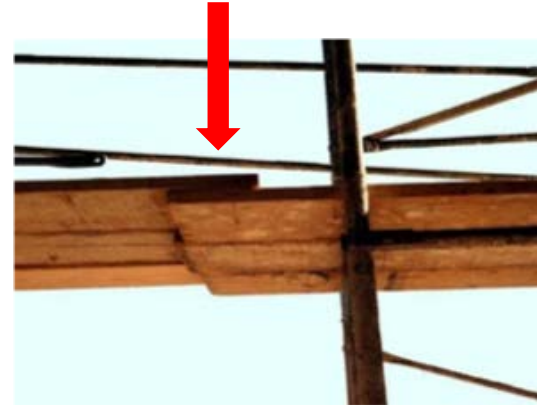

Large gaps in front edge of platform

For scaffold platform construction:

- No paint on wood platforms.
- Use scaffold grade wood.
- Must be fully planked between front upright and guardrail support.
- Component pieces used must match and be of the same type.
- Erect on stable and level ground.
- Lock wheels and braces.



The height of the scaffold should not be more than four times its minimum base dimension unless guys, ties, or braces are used.

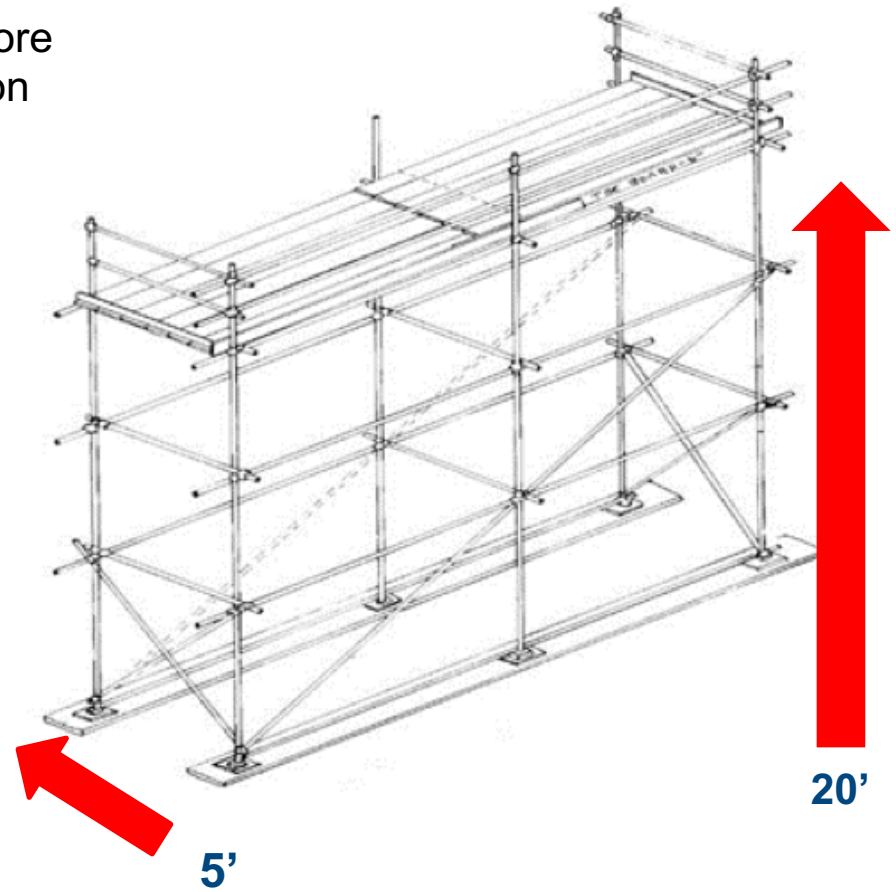

Each end of a platform, unless cleated or otherwise restrained by hooks, must extend over its support by at least 6 inches.



No Cleats

The structural members: poles, legs, posts, frames, and uprights, must be plumb and braced to prevent swaying and displacement.

- ▶ Restrain from tipping by use of guys, ties, or braces.
- ▶ Scaffold poles, legs, posts, frames, and uprights, with a height to base width ratio of more than 4:1, must be on base plates and mud sills or other firm foundation:
 - Vertically—every 20 feet or less for scaffolds less than three feet wide; every 26 feet or less for scaffolds more than three feet wide.
 - Horizontally—at each end; at intervals not to exceed 30 feet from one end.



This support is not adequate!

Provide access when scaffold platforms are more than 2 feet above or below a point of access.

Permitted types of access:

- Ladders, such as portable, hook-on, attachable, stairway type, and built-ins
- Stair towers
- Ramps and walkways
- May use building stairs and come out window



- ▶ Do not access the scaffold by cross braces.
- ▶ When using ladders, bottom rung should be no more than 24 inches high.
- ▶ You can use some end frames.
- ▶ Access is allowed from another scaffold, structure or hoist.



Do not access by cross braces

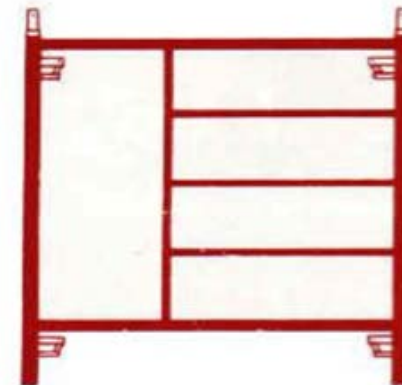

End Frame

For platforms suspended by ropes or wires:

- Rope must be capable of supporting six times the load.
- Employees should be trained to recognize hazards.
- Secure/tie to prevent swaying.
- Support devices must rest on surfaces that can support four times the load.

A competent person must:

- Evaluate connections to ensure the supporting surfaces can support load.
- Inspect ropes for defects before shift.
- PFAS must have anchors independent of the scaffold support system.



Employees can't be on a moving scaffold unless:

- Surface is level
- Height to base ratio is 2 to 1
- Outriggers are installed on both sides of scaffolds

Employees can't be on scaffold part beyond the wheels.
A competent person must be on site to supervise.

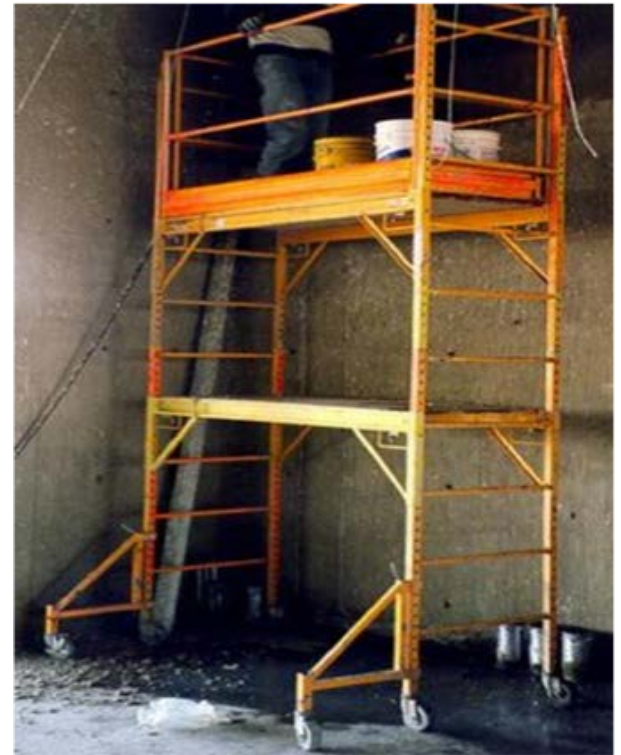

Cinder blocks or other similar materials should not be used to support a scaffold because they could be crushed.

- A. True
- B. False

Cinder blocks or other similar materials should not be used to support a scaffold because they could be crushed.

- A. True**
- B. False**

Fatal Fact – Moving a Lift

Employee was operating an aerial lift, with an extendable boom rotating work platform.

The boom was fully extended and the machine apparently ran over some bricks, causing the boom to flex or spring, throwing the employee from the basket.

The employee fell 37 feet to a concrete surface!



Do not load scaffolds or scaffold components in excess of their maximum intended loads or rated capacities, whichever is less.

Shore Scaffold:

Supported scaffold which is placed against a building or structure and held in place with props.



Lean-to Scaffold:

Supported scaffold which is kept erect by tilting it toward and resting it against a building or structure.

- ▶ Don't work on snow or ice covered platforms or during storms or high winds.
- ▶ Use tag lines on swinging loads.
- ▶ Protect suspension ropes from heat & acid.



A covered scaffold has special wind load considerations.

A laborer was working on the third level of a tubular welded frame scaffold which was covered with ice and snow.

The scaffold was not fully decked, there was no guardrail and no access ladder.

The worker slipped and fell, head first, 20 feet to the pavement below.



A guardrail or personal fall arrest system is required on all sides except the side where the work is being done.



A competent person:

- Is capable of identifying and promptly correcting hazards.
- Determines if it's safe to work on a scaffold during storms or high winds.
- Trains workers to recognize hazards.
- Selects qualified workers to conduct work.



A competent person must inspect scaffolds and scaffold components for visible defects before each work shift, and after any occurrence which could affect a scaffold's structural integrity.

Defective parts must be immediately repaired.



Deformed bearer

Scaffolds can only be erected, moved, dismantled or altered under the supervision of a competent person.

Competent persons select and direct these workers and determines the feasibility of fall protection.



Which of the following statements is correct?

- A. A Competent Person must inspect scaffolds for defects and hazards.
- B. A Competent Person selects and directs workers to construct scaffolds.
- C. A Competent Person trains workers to recognize hazards
- D. All of the above.

Which of the following statements is correct?

- A. A Competent Person must inspect scaffolds for defects and hazards.
- B. A Competent Person selects and directs workers to construct scaffolds.
- C. A Competent Person trains workers to recognize hazards
- D. All of the above.**

**Train employees on scaffold hazards and procedures to control the hazards.
The training must include:**

- Nature of electrical, fall, and falling object hazards
- How to deal with electrical hazards and fall protection systems
- Proper use of the scaffold
- Scaffold load capacities



Train employees involved in:

- Erecting
- Disassembling
- Moving
- Operating
- Repairing
- Maintaining
- Inspecting a scaffold to recognize its hazards and the correct procedures to use



Follow safety procedures and avoid these hazards:

- Falls from elevation
- Bad planking
- Scaffold collapse
- Getting struck by falling tools or debris
- Electrocution



Remember:

- ▶ Use appropriate scaffold construction methods:
 - Erect, move, or alter scaffold properly.
 - Protect from falling objects or tools.
- ▶ Ensure stable access.
- ▶ Use a competent person to:
 - Train on scaffold construction and the hazards involved with scaffolds.
 - Inspect scaffold before each shift and after alterations.
 - Determine fall protection requirements.

Congratulations! You have completed the
Scaffold Safety module.
Click [here](#) and take the final quiz.